

# Electronic

## Ballast Systems

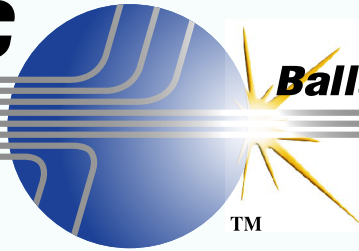

A 19kw.  
EBS  
module

## For Precision Lamp Control

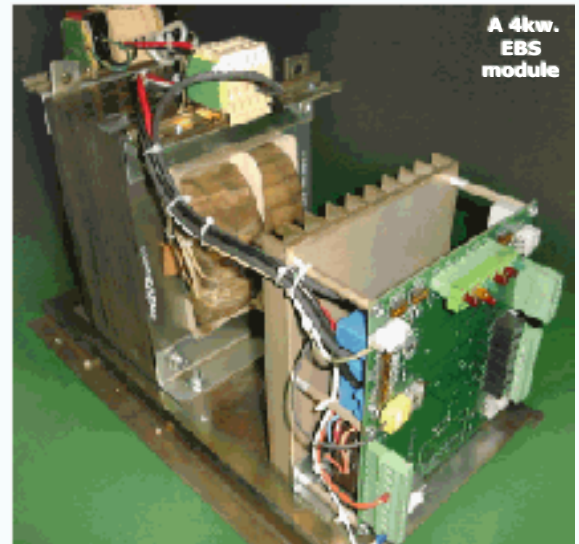

A 4kw.  
EBS  
module

### Control Features

- Fully integrate lamp control with the curing process
- Continuously variable lamp intensity from 10% to 100%
- Rapid lamp starts: as little as 10 seconds
- PC/PLC/POT control compatible
- Multiple ballast status indicators
- Operates mercury, gallium or halide lamps

### Packaging Benefits

- Drop in power supply, pre-wired
  - Broad power range: 100 to 100,000 watts
  - More efficient than magnetic ballasts
  - Save energy, reduce heat build up
  - Less maintenance: no high voltage caps or relays
  - Multiple input and output voltage options
- The Electronic Ballast Systems (EBS)  
TAS get the licensee, design & manufacture  
in Thailand under licence from :  
Nicollet Technologies Corporation USA.

### End User's Gain

- Precision product curing
- Tailor U.V. intensity to product chemistry
- No more overcure: precise undercure when desired
- Ramp U.V. output with web/belt speed
- Reduce substrate heat: improve print registration
- Higher production/longer bulb life/lower cost



**TAS UV Curing Co., Ltd.**

33/17 Moo 5, Kukoot, Lumlookkar, Pathumtani Thailand. 12130

Tel: (66) 2987-7660-3 Fax: (66) 2987-7664

Http://www.tasuvcuring.com

E-mail : sale@tasuvcuring.com,

tasuvcuring@yahoo.com,

tasthai@yahoo.com

Your Local Representative

# What is the Electronic Ballast Systems?

TAS UV Curing's new Electronic Ballast System (EBS) is a variable intensity power supply and control system for powering UV lamps. This revolutionary new technology has been granted two patents, with three more pending. The EBS was developed to solve the problems associated with conventional magnetic ballasts. As a result, it is now possible to fully integrate control of the UV lamp with curing system.

## **Improvements over conventional ballasts include:**

### **High Reliability**

The EBS replaces high-voltage capacitor banks and mercury-filled relays with a highly reliable electronic control. Reliability of the EBS measured four times better than a magnetic ballast with relays and capacitor banks, based on military reliability prediction methods.

### **Continuously Variable Lamp Power**

Power to the lamp is continuously variable over a range of 10% to 100% instead of two or three steps. Power is precisely controlled with a potentiometer, 0-5V, 0-10V, or 4-20mA control signal. The control input easily interfaces to a computer or programmable controller.

### **Simple Installation**

Completely factory pre-wired, the EBS eliminates labor intensive wiring of relays and capacitor banks. The user only needs to connect input power, lamp leads, and a control input.

### **Status Indicators**

Five status indicators show if power is applied, the operating mode (warmup or run), and if a lamp-out or overcurrent fault has occurred. Corresponding relay contacts can connect to a computer or programmable controller.

### **Accommodates a Range of Different Lamps With One Ballast Model**

One EBS model can have six or more output voltage selections to operate a range of different lamps with similar current ratings. Compared to the old "separate ballast for each bulb" limitation of magnetic ballasts, the EBS will dramatically reduce your inventory requirements.

### **Rapid Lamp Starting**

Using Profiled Current™ during warmup, time from ignition to full-power lamp-really can be as short as ten seconds. Start current is user-adjustable.

### **Standard Mercury, Gallium, or Halide Lamps**

An optional ignitor circuit can be added to the EBS for low-temperature starting, or for operating metal-halide or gallium-doped lamps.

### **Input Voltage Options**

The customer can select from one to six input voltage options on any EBS model, covering the range from 120 V. to 575V.

### **Automatic 50/60 Hz.**

International models automatically adapt to 50 or 60 Hz. input frequency.

### **Reduced Size & Weight**

A typical EBS is 25% smaller and lighter than a magnetic ballast system.

### **High Efficiency-Lower Operating Costs**

The EBS performs more efficiently than magnetic ballast, resulting in reduced energy cost, and reduced operating temperature.

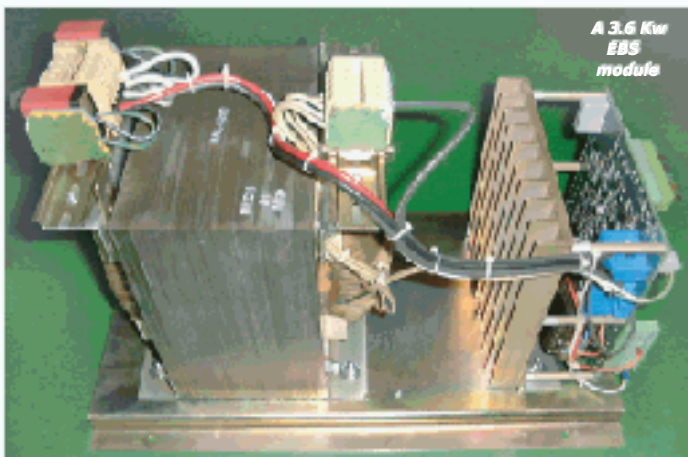

# How does the Electronic Ballast System work?

The Electronic Ballast System (EBS) consists of a power transformer, an SCR module, and a control circuit board mounted on a common base (see back cover). A block diagram of the system is shown at the right. The main element of the ballast is the power transformer. It scales the input voltage on the primary side to the appropriate lamp voltage on the secondary side. The power transformer also contains a built-in leakage inductance to help stabilize lamp impedance and limit current. Power to the lamp is controlled by a technique known as phase-angle modulation. With this method, the SCR module blocks portions of the line input voltage, while allowing other portions to pass. The ratio of passing to blocking determines how much power gets to the lamp. The control circuit measures the actual lamp current, compares it to the setpoint, and drives the SCRs with the proper phase angle.

## Closed Loop Lamp Current Control

One of the primary features of the EBS is that it uses feedback to maintain precise control over lamp current. Superior regulation is maintained over variations in temperature, input voltage, and lamp condition. This eliminates a typical problem with magnetic ballasts- that lamp current depends on a high voltage capacitor, the value of which has a  $\pm 20\%$  tolerance.

## Electronically Simulated Capacitor

Another feature of the control circuit is that it makes the EBS behave as if there were a capacitor in series with the lamp, even though none is. This is necessary because gas discharge lamps tend to become rectifiers- drawing current in only one direction- unless any DC through the lamp is eliminated. DC through the lamp causes saturation in the power transformer, mercury migration in the lamp, and other related problems. The patented circuit measures any DC offset, and independently adjusts the phase angle of each SCR, eliminating any DC in the lamp and transformer. The EBS is therefore able to

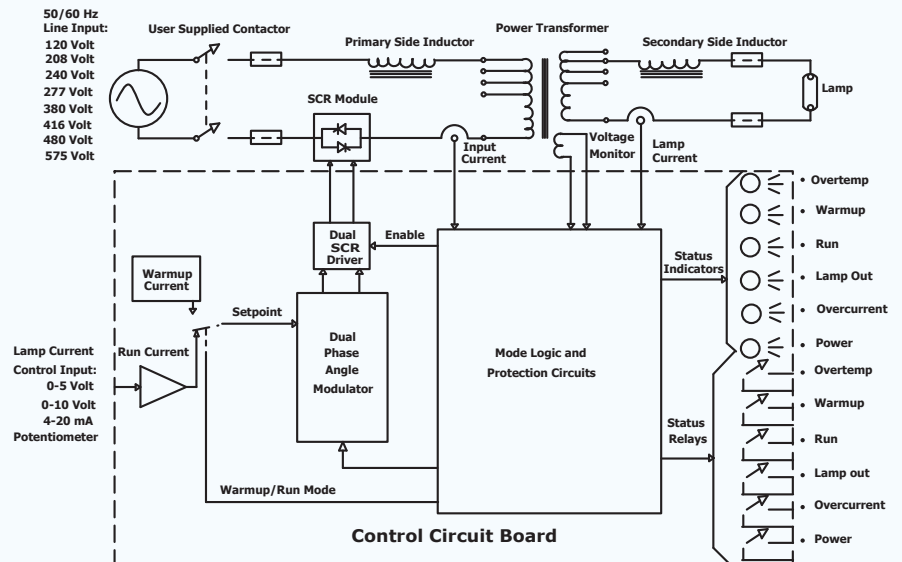

eliminate the large, unreliable capacitor banks that magnetic ballasts rely upon

## Controlled Warmup Mode

When the lamp is first ignited, the EBS drives the lamp current to the specified warmup current. That warmup current is maintained until the lamp reaches the correct operating voltage. At that point, control of lamp current switches from the warmup current to the run current, controlled via the control input. Warmup current is adjustable from less than 100% to more than 300% of the normal lamp run current. Setting the warmup current at the upper end of its range can bring lamps from ignition to full power in as little as ten seconds.

## Protection Circuits

The EBS has built-in protection circuits for the safety of the operator and equipment. These circuits shut down the ballast and signal a fault condition if abnormal operation is detected. If the input current is too high, an overcurrent fault is reported. If the lamp fails to start or extinguishes during operation, a lamp out fault is reported. The fault signals are indicated by LEDs on the circuit board and also by relay contacts for remote signaling.

# Electronic Ballast System

## Physical Size and Weight

**KVA RATING FROM LAMP LENGTH AND WATTS PER INCH**

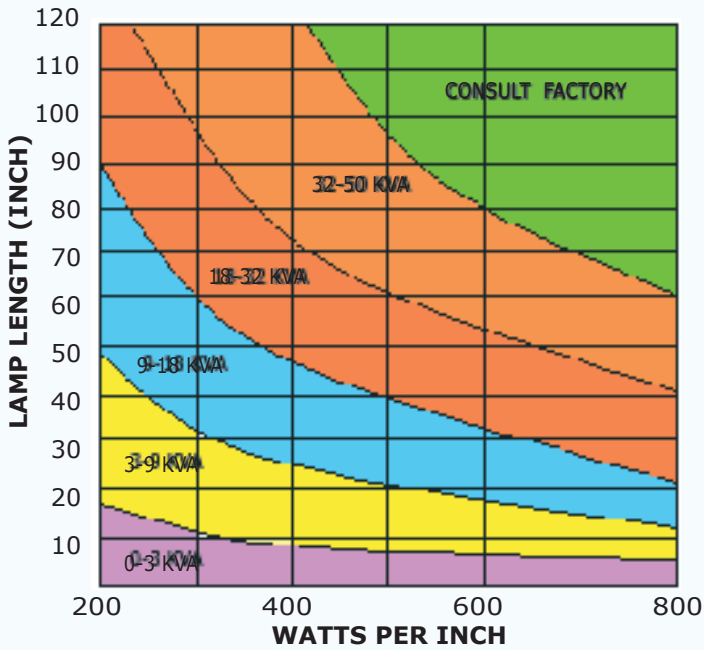

**KVA RATING FROM LAMP VOLTS AND LAMP CURRENT**

LAMP VOLTAGE	3600	3300	3000	2700	2400	2100	1800	1500	1200	900	600	300
LAMP CURRENT (AMPS)	5.0	7.5	10.0	12.5	15.0	17.5	20.0	27.0	36.0	45.0	54.0	
	27.0	36.0	45.0	54.0								
	25.9	34.5	43.1	53.3								
	24.8	33.0	41.3	49.5								
	23.6	31.5	39.4	47.3								
	22.5	30.0	37.5	45.0	52.5							
	21.4	28.5	35.6	42.8	49.9							
	20.3	27.0	33.8	40.5	47.3	54.0						
	19.1	22.5	28.1	38.8	39.4	45.0						
	18.0	24.0	30.0	36.0	42.0	48.0						
	16.9	19.5	24.4	29.3	34.1	39.0						
	15.8	21.0	26.3	31.5	36.8	42.0						
	14.6	19.5	24.4	29.3	34.1	39.0						
	13.5	18.0	22.5	27.0	31.5	36.0						
	12.4	16.5	20.7	24.8	28.9	33.0						
	11.3	15.0	18.8	22.5	26.3	30.0						
	10.1	13.5	16.9	20.3	23.6	27.0						
	9.0	12.0	15.0	18.0	21.0	24.0						
	7.9	10.5	13.1	15.8	18.4	21.0						
	6.8	9.0	11.3	13.5	15.8	18.0						
	5.6	7.5	9.4	11.3	13.1	15.0						
	4.5	6.0	7.5	9.0	10.5	12.0						
	3.4	4.5	5.6	6.8	7.9	9.0						
	2.3	3.0	3.7	4.5	5.3	6.0						
	1.1	1.5	1.9	2.3	2.5	3.0						

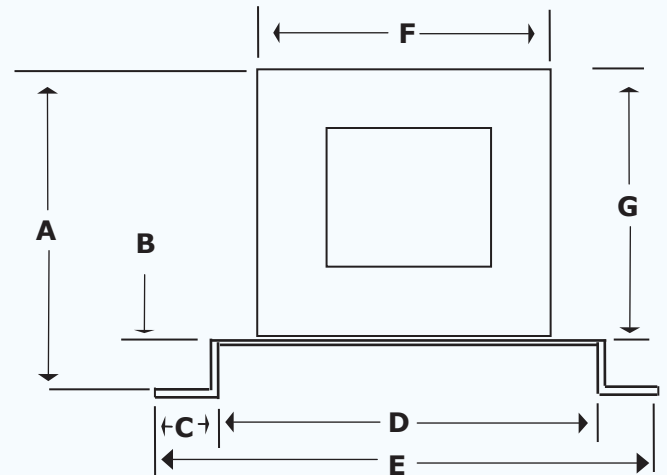
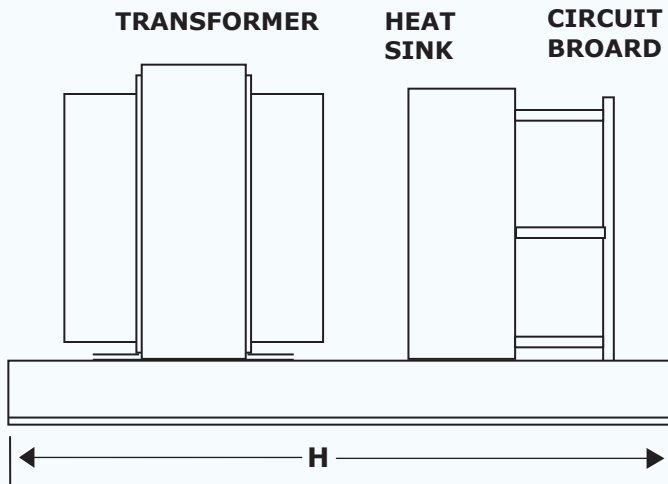

**SIZE 0-3 KVA**

- A = 8 3/4"
- B = 3/4"
- C = 1"
- D = 7 1/2"
- E = 9 1/2"
- F = 6 11/4"
- G = 7 1/2"
- H = 12"

Approx Weight  
3.0 KVA = 75 lbs.

**SIZE 3-9 KVA**

- A = 10 1/4"
- B = 3/4"
- C = 1"
- D = 8 1/2"
- E = 10 1/2"
- F = 7 1/2"
- G = 9"
- H = 16"

Approx Weight  
3.0 KVA = 75 lbs.  
9.0 KVA = 120 lbs.

**SIZE 9-18 KVA**

- A = 12 3/4"
- B = 3/4"
- C = 1"
- D = 11"
- E = 13"
- F = 10"
- G = 12"
- H = 18"

Approx Weight  
9.0 KVA = 120 lbs.  
18 KVA = 330 lbs.

**SIZE 18-32 KVA**

- A = 15 3/4"
- B = 3/4"
- C = 1"
- D = 13 1/2"
- E = 15 1/2"
- F = 12 1/2"
- G = 15"
- H = 20"

Approx Weight  
18 KVA = 330 lbs.  
32 KVA = 455 lbs.

**SIZE 32-50 KVA**

- A = 15 3/4"
- B = 3/4"
- C = 1"
- D = 13 1/2"
- E = 15 1/2"
- F = 12 1/2"
- G = 15"
- H = 26"

Approx Weight  
32 KVA = 455 lbs.  
50 KVA = 575 lbs.